



## **FTTN - Fibre to the Node**

The Cost Effective Solution for Telecom  
Broadband Infrastructure Deployment



KRONE

## Broadband Applications

Broadband applications require communication technology offering data traffic speeds above 1 Mbps. Many of the communications applications and services that were available in the year 2000 were designed for narrow-band application speeds (below 56 kbps). These applications included limited graphic web browsing, text based on-line shopping, email and word processor file transfer. Low cost broadband services such as xDSL systems provide a tremendous opportunity for the development of richer, more enhanced applications. These applications require services such as streaming video, rapid image file transfer or high-speed file transfer services.

There are hundreds of applications driving the demand for high speed data transfer services that can be provided via xDSL transmission: distance learning, high graphic on-line commerce, video and audio entertainment, interactive advertising, news and other information services, advanced manufacturing process, media production, remote security, public safety, telemedicine, utility management, advanced communication system and transportation. Much of the demand for broadband data access has come from the Internet. The Internet or World Wide Web (WWW) has had a profound impact on our lives – both on a personal and business basis. The Internet's global collection of inter-connected computer networks has become the medium of choice for dissemination of knowledge and connectivity for both individuals and corporations. The Internet is transforming the world into an "Information society". This medium has created an awareness of many new information services, and these new information services are often best delivered via rapid speed data communication services. Customers do not care or need to know how the underlying broadband communication technologies function. They only care that technology works for whatever applications they want to use. Broadband technologies, such as xDSL, merely provide a system that

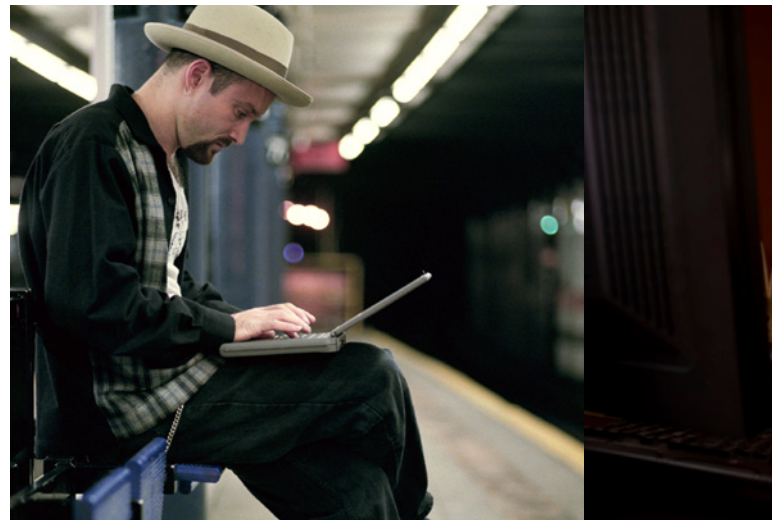

enables applications to fulfill the needs or desires of end-users.

Today, access to the Internet is an integral part of our society in touching business, educators, law enforcement, families, and so on. These consumers are hungry not just for simple applications such as email, but for rich, networked multimedia ones. ADSL utilizes existing infrastructure and allows high-speed digital data and analog voice to be carried simultaneously over a common copper local loop. High speed connectivity is Today, access to the Internet is an integral part of our society in touching business, Service providers are adapting their networks and strategies to meet the demand for high bandwidth services and applications at reduced cost. Some service providers are attempting to capture high bandwidth customers by offering access to key information services providers (e.g. a specific Internet services or digital video provider). The customer's key interest in high bandwidth service includes speeding up large file transfers, viewing high-resolution images and enabling multimedia application such as streaming audio and video.





All in all, xDSL service gives service providers other business opportunities to extend their business as revenues from IDD and mobile drop rapidly. The twisted pair copper cable under the ground is a big asset for Telecom operators, especially in the last mile of the network. This unique property must be fully utilized. In South Korea as an example, the saturation percentage is around 33% of the fixed-line telephone subscribers – 50 million population, 38 million telephone lines and 13 million broadband users. With a total population in Asia of around 1.9 billion, with 308 million telephone lines and 12 million xDSL subscribers in 2008, there is huge potential growth to offer advanced services cost-effectively by utilizing the existing copper lines..

### Broadband Deployment.

The most important element of broadband deployment is fiscal. The current market drivers for operators are to increase APRU for existing customers, reduce churn to competitors, maximize return on existing assets and to

generate new services. Revenue streams are all under attack and margins are declining.

- International call rates and margins have plummeted in the last 7 years.
- Local call rates and STD rates have declined dramatically.
- Competition exists in every segment of the market.

The ability to cross-subsidize residential market expansion through international and business class services has been eroded. Regulators and governments have established an environment of competition and licensing on all revenue streams. Capital spending cannot be funded from annual revenues. In reality telecommunications has had to become a competitive business and is no longer a national unified service. The glory days of monopoly service have gone. Is this a bad thing? In general this has actually lead to an increase in demand because of reduced prices. For operators it has dynamically changed the way they do business. Broadband (ADSL) deployment is the current key driver but in itself is only a stepping stone to the future.

The ITU FSAN (Full Service Access Network) model set out the future build scenario for modern broadband development.

The requirement for operators will be to provide a dynamic, high speed, flexible network with intelligence decentralized. The current model of a five kilometer circle of star deployed copper cross-connection cabinets will not meet future network needs. Short copper loops, to allow high bandwidth, can only be provided when active equipment is deployed in nodes nearer customers. The goal of a fibre to every home is the ideal deployment method but fiscally the cost of individual terminations is not yet feasible.

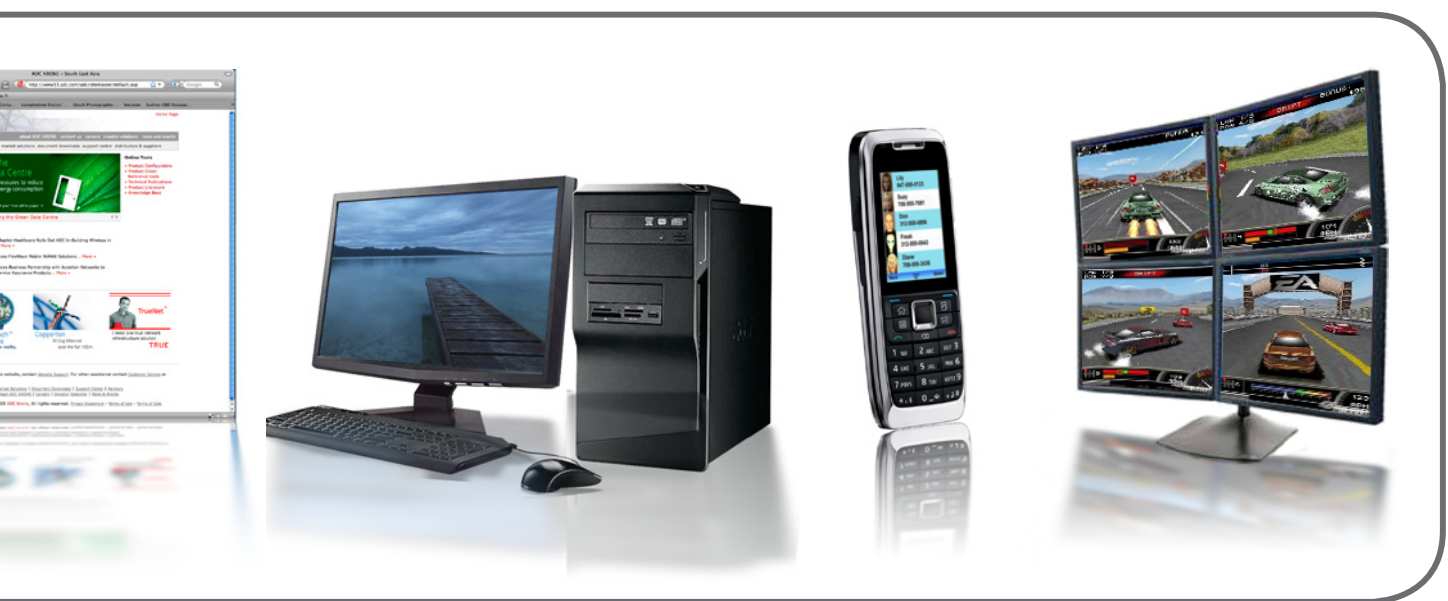

A ring and star fibre distribution system with active equipment deployed at wireless or copper access point within easy reach of customers gives operators greater flexibility at a better cost of investment. These active equipment points will need to be installed in leased space within existing buildings or in street side active cabinet. Commercially the physical deployment will be governed by the cost and access to these equipment nodes.

Different countries and different legislation will ensure that a commercially viable deployment options in one country, state or city may not be as viable in another.

Normal network planning activity was a well-trodden path that has successfully served the needs of yesterday's network. Today planners need to be a little more radical and try to second-guess the future. This is, of course, not easy and mistakes will be made. Planners have always worked to a known destination and now they have to work to an unknown and a less predictable future.

**Some things are definite**

- Full NGN IP switching will come.
- Customers will demand more bandwidth
- The operator's need increase their network's bandwidth capacity may be driven as much by competition as by demand.
- Electronics and signal recovery will get better.
- Copper loops must get shorter.
- Telephone dial tone will not be the only service offered.
- People will want entertainment choices on demand.
- Fibre will be handled more and will need to become more robust at connection points.

- Wireless may replace physical connections in the "last mile".
- QoS demands will increase - losing dial tone is one thing but losing your 300 Channels of TV and High Speed LAN will be a major issue.
- People will still want a bell to ring when they get a call.
- Fixed line operators must go for a triple-player service offering.

**FTTN**

In order to shorten the copper local loop, fiber needs to move closer to the subscribers. Currently FTTx architecture has FTTN / C, FTTB. (See diagram 1.)

The deployment of FTTx must be planned strategically. Four main factors must be considered to find the best solution.

- Bandwidth required by users
- The reach of the subscribers
- Current infrastructures and resources
- CAPEX and OPEX

It is undeniable that FTTx will ultimately become FTTH. The transition plan and schedule is the key to success.

New builds and upgrading projects will be planned separately. In future, as the PON and VDSL equipment price drops, FTTB (PON) + VDSL2 will be the most economical upgrade model. It has the better advantages for CAPEX and bandwidth improvement.

According to Infonetics statistics, FTTN/C, FTTB are currently the models most used by world-wide carriers. Only certain carriers such as NTT of Japan is proactively

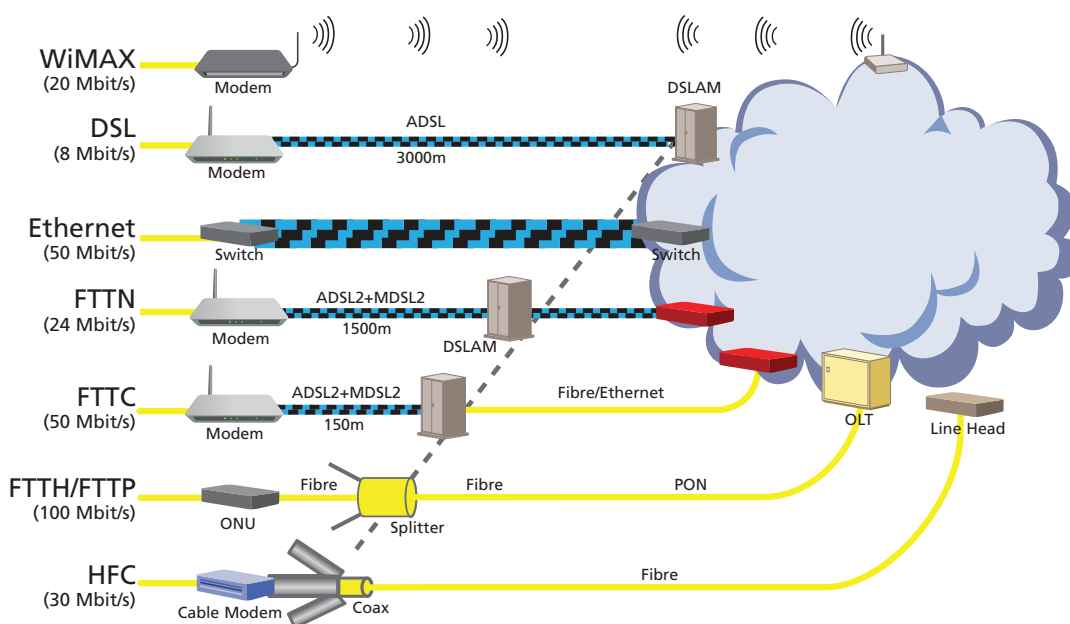

deploying FTTH for new build projects. Even so, NTT still have 30 percent of their subscribers under the FTTB + VDSL2 model.

### How to cope with all this?

Unfortunately there is no easy answer. Operators must meet the demands of today and control CAPEX but they also need to "future proof" for tomorrow at the same time.

Fibre hasn't changed too much in the last 25 years, the main change has been in the terminal equipment. The terminal equipment has become smaller, faster and consumes less power. To deliver higher bandwidth to subscribers, more active equipment needs to be deployed in the external network.

The issue of power, back up power and what to do in the event of a failure consume more discussion time than probably any other subject. In an ideal world the utility provider would see the potential market and offer a standby DC feed giving the telecommunications operator an easy solution. This is not likely to happen. Operators need to make some hard choices, provide their own back-up feed through copper pairs in their fibre cable, provide batteries or allow systems to fail when main electrical power fails.

### This choice needs to be made first. Possible solutions are

- A DC feeder pair inside fibre cables - optimum gauge and current load?
- A parallel DC feeder pair run in sub-duct next to fibre - optimum gauge and current load?
- Local DC support facilities with their own network to connect active equipment.
- Underground battery storage.
- Above ground battery storage.
- Locally negotiated agreements to tap UPS supplies from commercial buildings.

These are not easy questions and all have pluses and minuses, but a choice must be made in order to take commercial advantage of FTTN network deployment and to meet customer expectations. When the power choice is made, then planners can explore the options available to allow future network expansion and growth.

Some legislation still exists that operators have to provide an "essential" service at all times. With the proliferation of mobile telephones is this still necessary? Operators and government bodies around the world have yet to resolve this question. In the meantime, planners must still take ever-available essential service into account.

The core issue here is that higher bandwidth can only be deployed on short copper loops from fibre fed active equipment. This equipment has to be housed within a few hundred meters of customer locations. The options are to deploy this equipment in external cabinets or leased commercial office space. With current legislation the most cost effective option would be external cabinets in urban, industrial and rural areas and some deployed in commercial areas. Most commercial areas, however, would be more cost effective in leased office space. One of the issues is flexibility of physical access. There is no point having an active equipment node in a building that closes at 6:00pm and access after that time is restricted or even impossible.

ADC does provide a consistent, reliable, high performance FTTX, FTTB, FTTN and FTTH connectivity solutions, addressing the challenges of cost-effective, flexible, reliable, scalable bandwidth delivery.

If you would like to learn more, please contact your local ADC KRONE representative.

WHITE PAPER



KRONE



**[www.adckrone.com/sg](http://www.adckrone.com/sg)**

SINGAPORE 100 Beach Road #18-01 Shaw Tower, Singapore 189702

**INDONESIA**

Ph: +62 21 520 0231, Fax: +62 21 522 1312

**PHILIPPINES**

Ph: +63 2 848 9901, Fax: +63 2 848 9904

**THAILAND**

Ph: 662 512 3688, Fax 662 512 4747

**MALAYSIA**

Ph: +603 2615 0146, Fax: +603 2615 0147

**SINGAPORE**

Ph: +65 6394 3800, Fax: +65 6297 5035

**VIETNAM**

**Hanoi:** Ph: +844 934 3968, Fax: +844 934 3956

**HCMM:** Tel: (84-8) 8 219 225, Fax: (84-8) 8 219 181

ADC Telecommunications, Inc., P.O. Box 1101, Minneapolis, Minnesota USA 55440-1101

Specifications published here are current as of the date of publication of this document. Because we are continuously improving our products, ADC reserves the right to change specifications without prior notice. At any time, you may verify product specifications by contacting our headquarters office in Minneapolis. ADC Telecommunications, Inc. views its patent portfolio as an important corporate asset and vigorously enforces its patents. Products or features contained herein may be covered by one or more U.S. or foreign patents. An Equal Opportunity Employer

**401116SG 03/09 Revised © 2009 ADC Telecommunications, Inc. All Rights Reserved.**